

[sonics.com](http://sonics.com)



**SONICS**<sup>®</sup>  
SONICS & MATERIALS, INC.

**vibra<sup>™</sup>cell**



# TABLE OF CONTENTS

## **A** Sonics

Pg. 1-2 Introduction

## **B** Large volume ultrasonic liquid processors (200 $\mu$ l – 1L volumes)

Pg. 3 750 watt system

Pg. 4-5 500 watt systems

Pg. 6-12 Accessories for 750 and 500W systems

Pg. 13 Sonochemistry accessories

## **C** Small volume ultrasonic liquid processors (200 $\mu$ l – 150mL volumes)

Pg. 14-15 130 watt systems

Pg. 16 50 watt system

Pg. 17-18 Accessories for 130 and 50W systems

## **D** Production volume ultrasonic liquid processors (1L – 50L volumes)

Pg. 19 1500 watt system

Pg. 20 High volume flow cell

Pg. 21 2500 watt system

## **E** OEM

Pg. 22 Ultrasonic components

## **F** Atomizer

Pg. 23 Ultrasonic atomizer

## **G** FAQ

Pg. 24 Frequently Asked Questions





**Dear Colleague,**

At Sonics, we believe that technological innovation and collaboration are the cornerstones on which to build a better product. We are research driven, and continually refine and broaden our product line by aggressively investing in R&D and working closely with laboratory and production personnel around the globe. The instruments displayed in this catalog are the product of that synergy.

On behalf of all of us at Sonics, I would like to take this opportunity to thank each and every one of our customers for their trust in our ability to meet their needs. We sincerely appreciate your loyalty and continued support.

Robert Soloff, CEO

Lauren Soloff, President



Vibra-Cell™ is the only ultrasonic processor that is backed by a **three-year warranty** that covers both parts and labor. In the unlikely event that your instrument should require servicing within that period, it will be repaired free of charge.



Sonics headquarters and manufacturing facility in Newtown, CT, USA.





# OVER 50 YEARS OF ULTRASONIC EXPERIENCE

**POWER SUPPLY**



An ultrasonic processor has three main components:  
**Power supply, Converter and Probe** (also known as a horn).

The ultrasonic electronic power supply transforms AC line power to high frequency electrical energy. The power supply has a control panel allowing adjustment of several parameters including time and amplitude.

**CONVERTER**



The power supply delivers high voltage pulses of energy at 20 kHz to drive a piezoelectric converter. A high voltage cable connects the converter to the power supply. The converter transforms electrical energy to mechanical vibration.

**PROBE/HORN**



This vibration is amplified based upon the shape of the probe and transmitted down its length, into the liquid sample. Probes attach to the converter via a threaded stud. During operation, the probe is resonating, meaning that it is expanding and contracting longitudinally. The movement of the probe is controlled by the amplitude setting. The effective amplitude setting must be determined through empirical testing by the end user.

## CHOICE OF ULTRASONIC PROCESSING METHODS:

### PROBE SONICATION

Immersing a probe directly into a beaker or vessel is the most common way to process a sample. High intensity ultrasonic energy is transmitted directly into the liquid, causing cavitation and processing the sample quickly and effectively. Several probe options and accessories are available to handle a variety of applications and sample volumes. Probes are made from a titanium alloy (Ti-6Al-4V) due to many factors including its acoustical properties.



### CUP HORN PROCESSING

The cup horn can process multiple sealed tubes or vessels at one time without contact with an ultrasonic probe. This technique is often described as a high intensity ultrasonic bath. Cup horns are recommended when working with very small volumes or infectious materials because foaming and aerosolization are eliminated. The ultrasonic energy is transmitted from the horn, up through the water and into a vessel or multiple sample tubes.





# VCX 750

750 Watts

Processing Volume: 200µl – 1L\*

The **VCX 750** is a powerful and versatile ultrasonic liquid processor.

Using a variety of accessories, the system can process a wide range of sample types and volumes for many different applications.

The **VCX 750** is microprocessor based and programmable. Intuitive screens are user friendly and easy to navigate. The 750 watt power supply has the capability of operating our largest assortment of horns and accessories.

A standard ½" diameter probe with replaceable tip is included and many optional accessories are available to meet the needs of most any application.

## FEATURES:

- Programmable
- Variable power output
- 10 hour timer
- Pulse mode
- Wattage and Energy display
- Temperature monitoring
- Energy setpoint



(stand is optional)

Ordering information: Model no. **VCX 750**  
750 watt ultrasonic processor with ½" diameter probe and tool kit.

## SPECIFICATIONS

Power Output	750 watt maximum	Converter Cable	Part #201-0300
Frequency	20kHz	Length	6 ft. (1.8m)
Dimensions	H x W x D: 9.25 x 7.5 x 13.5" (235 x 190 x 340mm)		
Ultrasonic Converter	Part #CV334	Tool Kit	Part #381-0005
Diameter	2.5" (64mm)		Includes: 2 spanner wrenches and 1 open-end wrench
Length	7.25" (183mm)		
Standard Probe	Part #630-0220	Optional:	
Tip Diameter	0.5" (13mm) with replaceable tip	Stand with Clamp	Part #830-00459
Length	5.5" (139mm)	Sound Enclosure	Part #830-00427
Material	Ti6Al4V titanium alloy	Temperature Probe	Part #830-00060



\*The actual processing volume of a specific probe or accessory is application specific.



# VCX 500

500 Watts

Processing Volume: 200µl – 1L\*

The **VCX 500** offers 500 watts of power to handle a range of liquid processing applications. This model shares the same microprocessor based operating system and programming screens as the VCX750 system.

This model offers the same programmability as larger **VCX** versions.

A standard ½" diameter probe with replaceable tip is included and many optional accessories are available to meet the needs of any application.

## FEATURES:

- Programmable
- Variable power output
- 10 hour timer
- Pulse mode
- Wattage and Energy display
- Temperature monitoring
- Energy setpoint



(stand is optional)

Ordering information: Model no. **VCX 500**  
500 watt ultrasonic processor with ½" diameter probe and tool kit.

## SPECIFICATIONS

Power Output	500 watt maximum	Converter Cable Length	Part #201-0300 6 ft. (1.8m)
Frequency	20kHz		
Dimensions	H x W x D: 9.25 x 7.5 x 13.5" (235 x 190 x 340mm)		
Ultrasonic Converter	Part #CV334	Tool Kit	Part #381-0005 Includes: 2 spanner wrenches and 1 open-end wrench
Diameter	2.5" (64mm)		
Length	7.25" (183mm)		
Standard Probe	Part #630-0220	Optional:	
Tip Diameter	0.5" (13mm) with replaceable tip	Stand with Clamp	Part #830-00459
Length	5.5" (139mm)	Sound Enclosure	Part #830-00427
Material	Ti6Al4V titanium alloy	Temperature Probe	Part #830-00060



\*The actual processing volume of a specific probe or accessory is application specific.





# VC 505

500 Watts

Processing Volume: 200µl – 1L\*

The **VC 505** is a cost effective alternative to the VCX model. This 500 watt system offers the same processing power and choice of accessories as the VCX500 without temperature monitoring or energy set point programming.

A standard ½" diameter probe with replaceable tip is included and many optional accessories are available to meet the needs of any application.

## FEATURES:

- Programmable
- Variable power output
- 10 hour timer
- Pulse mode
- Wattage and Energy display



(stand is optional)

Ordering information: Model no. **VC 505**  
500 watt ultrasonic processor with ½" diameter probe and tool kit.

## SPECIFICATIONS

Power Output	500 watt maximum	Converter Cable Length	Part #201-0300 6 ft. (1.8m)
Frequency	20kHz		
Dimensions	H x W x D: 9.25 x 7.5 x 13.5" (235 x 190 x 340mm)		
Ultrasonic Converter	Part #CV334	Tool Kit	Part #381-0005 Includes: 2 spanner wrenches and 1 open-end wrench
Diameter	2.5" (64mm)		
Length	7.25" (183mm)		
Standard Probe	Part #630-0220	Optional:	
Tip Diameter	0.5" (13mm) with replaceable tip	Stand with Clamp	Part #830-00459
Length	5.5" (139mm)	Sound Enclosure	Part #830-00427
Material	Ti6Al4V titanium alloy		



\*The actual processing volume of a specific probe or accessory is application specific.



# ACCESSORIES FOR 750 AND 500 WATT SYSTEMS

## PROBES

Probes (sometimes referred to as horns) are attachments that act as mechanical amplifiers to increase the amplitude of vibration generated by the converter.



**TIP DIAMETER**  
1/2" (13mm)

**PART NO.**  
630-0220  
Threaded End  
630-0219  
Solid

**VOLUME**  
50-250mL

**AMPLITUDE**  
115µm



**TIP DIAMETER**  
3/4" (19mm)

**PART NO.**  
630-0207  
Threaded End  
630-0208  
Solid

**VOLUME**  
100-500mL

**AMPLITUDE**  
60µm



**TIP DIAMETER**  
1" (25mm)

**PART NO.**  
630-0210  
Threaded End  
630-0209  
Solid

**VOLUME**  
200-1,000mL

**AMPLITUDE**  
35µm

When driven at its resonant frequency, the probe expands and contracts longitudinally about its center. The distance the probe moves is measured as the amplitude. The greater the mass ratio between the upper section and the lower section, the greater the amplification factor, and the greater the peak-to-peak excursion at the tip of the probe. The amplitude setting can be adjusted on the power supply.

Probes with smaller tip diameters produce greater intensity of cavitation, but the energy released is restricted to a narrower, more concentrated field. Conversely, probes with larger tip diameters produce less intensity, but the energy is released over a greater area. The larger the tip diameter, the larger the volume that can be processed, but at lower intensity.



High gain probes produce higher intensity than standard probes of the same diameter and are recommended for processing difficult samples. Probes are fabricated from a high-grade titanium alloy (Ti-6Al-4V) because of its high tensile strength, good acoustical properties at ultrasonic frequencies, high resistance to corrosion, low toxicity and excellent resistance to cavitation erosion. They are autoclavable and available with threaded ends to accept replaceable tips, microtips and extenders. Probe tips will pit or erode over time and will need to be replaced. Replaceable tip probes are used with aqueous samples only. Solid probes can be used with all sample types including aqueous samples, organic solvents and low surface tension liquids. Contact Sonics for help selecting the proper probe or tip.

## REPLACEABLE TIPS

Standard 1/2", 3/4" and 1" probes are available with replaceable tips for use with water based samples. During use, tips erode and become less effective over time. A worn tip is easily removed and replaced.

**PART NO.**  
630-0406

**TIP DIAMETER**  
1/2" (13mm)

**PART NO.**  
630-0407

**TIP DIAMETER**  
3/4" (19mm)

**PART NO.**  
630-0408

**TIP DIAMETER**  
1" (25mm)





## TAPERED MICROTIPS

Two types of microtips are available to enable processing of samples in small vessels or tubes – a tapered microtip and a stepped microtip. The tapered microtip screws into the threaded end of the standard 1/2" (13 mm) probe in place of the replaceable tip. This combination is capable of generating very high amplitudes.

**TIP DIAMETER**  
1/16" (2mm)

**PART NO.**  
630-0417

**VOLUME**  
0.2-5mL

**MAX AMPLITUDE %**  
40

**AMPLITUDE**  
170µm



**TIP DIAMETER**  
1/8" (3mm)

**PART NO.**  
630-0418

**VOLUME**  
1-15mL

**MAX AMPLITUDE %**  
40

**AMPLITUDE**  
200µm



**TIP DIAMETER**  
3/16" (5mm)

**PART NO.**  
630-0419

**VOLUME**  
5-20mL

**MAX AMPLITUDE %**  
65

**AMPLITUDE**  
210µm



**TIP DIAMETER**  
1/4" (6mm)

**PART NO.**  
630-0420

**VOLUME**  
10-50mL

**MAX AMPLITUDE %**  
75

**AMPLITUDE**  
180µm



Tapered microtips attach to standard 1/2" probe (#630-0220).



**CAUTION:** Do not exceed the maximum amplitude limits. Operating above the limit may cause the microtip to fracture. Do not use a tapered microtip with a coupler.

## STEPPED MICROTIPS

The stepped microtip assembly consists of two parts, the coupler and the microtip. The coupler screws into the converter in place of the standard probe and due to the reduced diameter, it is capable of reaching into narrow, long necked vessels. The stepped microtip assembly can deliver lower amplitudes and is advantageous when processing samples under 1mL.

**COUPLER**

**PART NO.**  
630-0421



**TIP DIAMETER**  
1/16" (2mm)

**PART NO.**  
630-0423

**VOLUME**  
0.2-5mL

**MAX AMPLITUDE %**  
40

**AMPLITUDE**  
110µm



**TIP DIAMETER**  
1/8" (3mm)

**PART NO.**  
630-0422

**VOLUME**  
1-15mL

**MAX AMPLITUDE %**  
40

**AMPLITUDE**  
110µm



**TIP DIAMETER**  
1/4" (6mm)

**PART NO.**  
630-0435

**VOLUME**  
10-50mL

**MAX AMPLITUDE %**  
40

**AMPLITUDE**  
80µm



Stepped microtips attach to the coupler (#630-0421).



## EXTENDERS

Extenders screw into threaded end probes of the identical diameter in place of the replaceable tip. Extenders are recommended when working with tall, narrow vessels such as Erlenmeyer flasks and add 5" of length to a standard probe.



**PART NO.**  
630-0410

**SIZE**  
1/2" (13 mm) diameter  
5" (127 mm) long.

**PART NO.**  
630-0409

**SIZE**  
3/4" (19 mm) diameter  
5" (127 mm) long

**PART NO.**  
630-0444

**SIZE**  
1" (25 mm) diameter  
5" (127 mm) long

Longer extenders are available upon request.

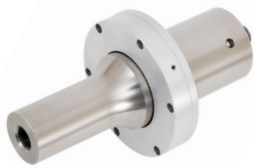

**PART NO.**  
BHN294T21

## BOOSTER

When connected between the converter and the probe, the booster acts as a mechanical amplifier that increases the amplitude of vibration by a factor of 2. The booster is compatible with the 3/4" and 1" standard probes. Boosters cannot be used with 1/2" probes.

## HIGH GAIN PROBES

High gain probes offer twice the amplitude when compared to standard probes of the same diameter and attach directly to the converter. High gain probes are not compatible with boosters.

**TIP DIAMETER**  
3/4" (19mm)

**PART NO.**  
630-0306

**TYPE**  
Solid

**VOLUME**  
100-500mL

**AMPLITUDE**  
115µm



**TIP DIAMETER**  
1" (25mm)

**PART NO.**  
630-0310

**TYPE**  
Solid

**VOLUME**  
200-1,000mL

**AMPLITUDE**  
65µm



## DUAL PROBE

The dual probe assembly enables a single ultrasonic processor to process two (25-500 mL) samples simultaneously. The assembly consists of an aluminum primary horn **PART NO. 630-0562** and two 3/4" (19 mm) solid probes **PART NO. 630-0208**. Center to center dimension between the probes is 4 1/2" (114 mm).

When used with a 750 watt ultrasonic processor, the dual probe is capable of delivering up to 375 watts per probe, meeting all EPA requirements specified in SW-846 method 3550.



**PART NO.**  
630-0525



## MULTI-ELEMENT PROBES

The high throughput multi-element probes increase productivity and minimize repetitive tasks by processing numerous samples simultaneously. Units are available with 4, 8, 16 and 24 tips and are compatible with either the 500 or 750 watt systems. Custom formatted multi-element probes are available upon request.

**4-ELEMENT**



**PART NO.**  
630-0559

**8-ELEMENT**



**PART NO.**  
630-0586

**16-ELEMENT**



**PART NO.**  
630-0699

**24-ELEMENT**



**PART NO.**  
630-0579

**TIP DIAMETER**  
1/8" (3mm)

**VOLUME**  
0.5-15mL

**AMPLITUDE**  
120µm



**PART NO.**  
830-00427

## SOUND ABATING ENCLOSURE

Ultrasonic processing produces high pitched noise, which originates from the vessel walls and the liquid surface. The sound enclosure reduces the noise to comfortable levels. A support rod and converter clamp are included. Access ports are available on both sides and the top of the enclosure.

**OUTSIDE DIMENSIONS:**  
(H x W x D) 30.5" x 13.5" x 13"  
(775 x 343 x 330 mm)

**INSIDE DIMENSIONS:**  
(H x W x D) 29" x 12.5" x 12"  
(737 x 318 x 305 mm)

## SUPPORT STAND WITH CLAMP

Securely support the ultrasonic processor with a chemically resistant plastic holder on a 5.5" x 9" cast-iron base with 0.5" diameter rod.

The converter clamp and support stand can be ordered separately.



**PART NO.**  
830-00451



**PART NO.**  
830-00116

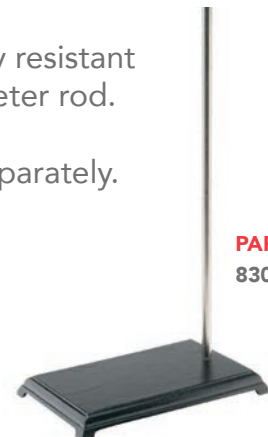

**PART NO.**  
830-00109

## MEDIUM VOLUME CONTINUOUS FLOW CELL

The flow cell enables continuous processing of 1L or greater volumes. The unit is made of 316L stainless steel and has ¼" (6mm) hose barb fittings. Maximum flow rate is 0.5L/min.

A ½" (13mm) solid tip flow cell probe is included and the volume of liquid inside the chamber with the probe installed is 65 ml. A variable speed pump is recommended but not included.

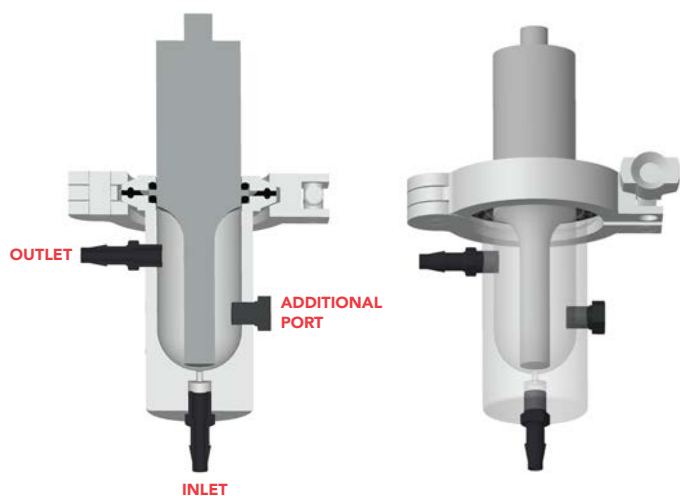

FLOW CELL ASSEMBLY

REPLACEMENT PROBE



PART NO.  
630-0651



PART NO.  
630-0644



## CHILLER

Ultrasonic processing generates heat which may be detrimental to many applications. The chiller automates the cooling process with a 400W cooling capacity and controls temperature from 5-45°C.

Two models are available. The chiller **PART NO. 830-00905** is compatible with the cup horn system and does not include an internal reservoir to hold water. This model recirculates and chills the water inside the cup horn. This feature is important because it maintains a constant water level which improves sample processing. The tubing and connector set must be ordered separately **PART NO. 309-4911**.

The chiller **PART NO. 830-00906** includes a 300mL internal water reservoir which enables it to be connected to any device that requires an external cooling system. This is the recommended chiller model for use when cooling the water jacket on a high volume flow cell.



## CUP HORN ASSEMBLY

The cup horn can process multiple sealed tubes or vessels at one time without contact with an ultrasonic probe. This method eliminates cross contamination, sample foaming, overheating and aerosolization which can all occur when using a probe. Most importantly the cup horn enables samples under 200µl to be effectively processed.

**VCX500 WITH  
CUP HORN, CHILLER,  
ENCLOSURE PACKAGE**

**PART NO.  
VCX500CCE**

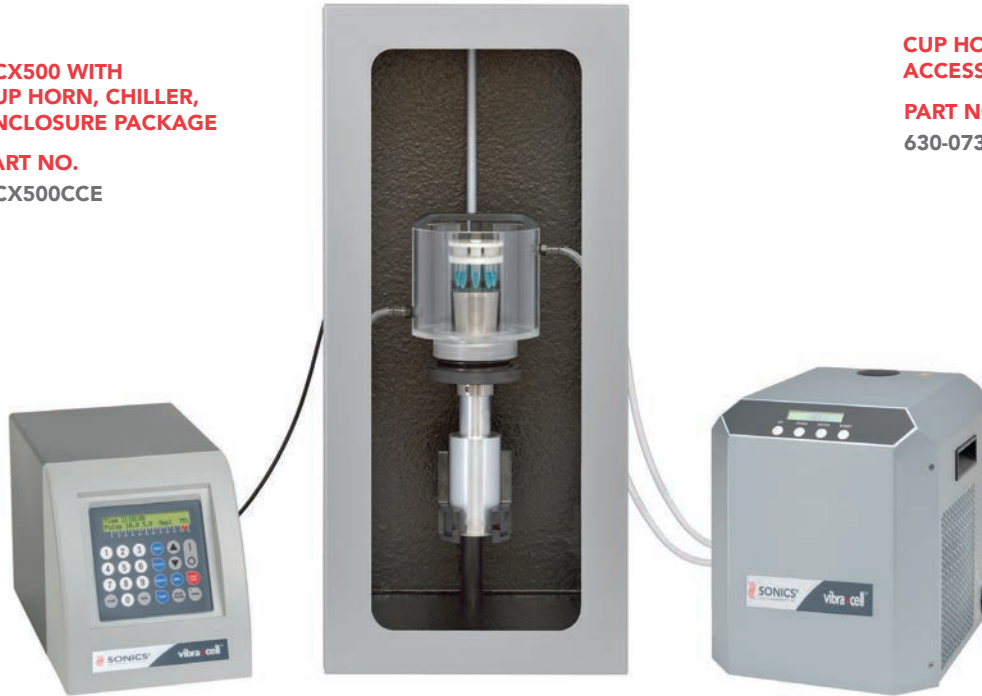

**CUP HORN  
ACCESSORY**

**PART NO.  
630-0731**



The water-filled cup horn is screwed onto the converter in place of a probe. Microtubes containing the samples are placed inside using specially designed tube holders. Multiple tube holders are available for various size tubes and vessels. Ultrasonic energy is transferred through the water and into the sample tubes.

Inlet and outlet ports enable cooling water to be circulated within the cup, inhibiting heat build up during extended operation. Use of the chiller is highly recommended and due to the high noise level created by the cup horn, a sound abating enclosure is required.

Note: Selecting the appropriate size and type of sample tube will greatly improve results. Contact Sonics for application assistance.

**HOLDER FOR (8) 1.5ML  
POLYSTYRENE TUBES**



**PART NO.  
830-00247**

**HOLDER FOR (8) 1.5ML  
POLYPROPYLENE TUBES**



**PART NO.  
830-00248**

**HOLDER FOR  
15ML TUBE**



**PART NO.  
529-0029**

**HOLDER FOR  
50ML TUBE**



**PART NO.  
529-0030**





## HEAVY DUTY SUPPORT ASSEMBLY

Supports the converter and multi-element probe with minimum deflection. Includes lab jack. Recommended when working with any multi-element horn.

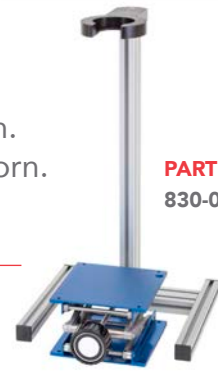

**PART NO.**  
830-00130



## LABORATORY JACK

Provides adjustable elevation from 2 1/2" (64 mm) to 10" (254 mm). Top plate: 6" x 6" (152 x 152 mm).

**PART NO.**  
830-00113

## ROSETTE GLASS COOLING CELLS

The rosette is a glass cell that enables uniform treatment at low temperatures. Fill the rosette with your liquid sample and place it in an ice bath. The ultrasonic energy forces the sample to circulate under the probe and through the cooling arms.



300mL Rosette

**PART NO.**  
830-00001

30mL Rosette

**PART NO.**  
830-00003



## JACKETED BEAKERS

The jacketed beaker is attached to a chiller or another cold water source. The chilled water is circulated around the liquid within the beaker maintaining the desired sample temperature.

10 mL cooling cell  
with water jacket

**PART NO.**  
830-00009

100 mL cooling cell  
with water jacket

**PART NO.**  
830-00010

## TEMPERATURE PROBE

Enables temperature monitoring from 1 – 100°C.

**PART NO.**  
830-00060



## REPLACEMENT CONVERTER



**PART NO.**  
CV334

## REPLACEMENT CONVERTER CABLE

6' (1.8m) length

**PART NO.**  
201-0300



## REPLACEMENT WRENCH SET

The 750 and 500W ultrasonic processors include 2 spanner wrenches and a 9/16" x 7/16" open end wrench.



**PART NO.**  
381-0005

## HAND HELD FREQUENCY METER

Check the frequency of energized probes, converters and boosters. Frequency range: 10.00 kHz - 80.00 kHz



**PART NO.**  
833-00012

## FOOTSWITCH

For hands-free operation with 10' (3m) cable.

**PART NO.**  
830-00004







# SONOCHEMISTRY EQUIPMENT

The chemical effects of ultrasound are diverse and include dramatic improvements in both stoichiometric and catalytic reactions. In some cases, ultrasonic treatment can increase reactivity by nearly a million-fold. It does so through the process of acoustic cavitation; the formation, growth and implosive collapse of bubbles in a liquid.

During cavitation collapse, intense heating of the bubbles occurs. The localized hot spots have temperatures in the range of 5000°C, pressures approaching 500 atmospheres, lifetimes of a few microseconds, and heating and cooling rates greater than 10<sup>9</sup> K/s. Of special interest for sonochemistry research, is the fact that cavitation generates highly reactive free radicals that greatly enhance chemical reactions.

Applications for chemical reactions exist in both homogeneous liquids and in liquid-solid systems. Ultrasound has also been found to be beneficial for the initiation or enhancement of catalytic reactions, in both homogeneous and heterogeneous cases.

## SONOCHEMICAL REACTION VESSELS

The adapter Part No. 830-00014 screws onto the special probe Part No. 630-0217 at the nodal point. The glass chamber slides onto the adapter and is secured in place as the bushing is screwed into the chamber compressing the O-ring. Moving the glass chamber up or down on the adapter allows the portion of the probe protruding out of the adapter to be immersed at the optimum depth into the sample.



**PART NO.**  
**830-00011**

4-10 ml reaction vessel. Two 14/20 side necks. Supplied with bushing and O-ring. Glass chamber height: 4 <sup>7</sup>/<sub>8</sub>" (123 mm).



**PART NO.**  
**830-00012**

10-50 ml reaction vessel. Bottom well capacity: 10 mL. Main body capacity: 50 ml. Two 14/20 side necks. Supplied with bushing and O-ring. Glass chamber height: 4 <sup>3</sup>/<sub>4</sub>" (120 mm).



**PART NO.**  
**830-00013**

40-250 mL reaction vessel. Three 14/20 side necks. Supplied with bushing and O-ring. Glass chamber height: 6 <sup>3</sup>/<sub>8</sub>" (162 mm).



## ADAPTER

5" (127 mm long). Stainless steel. Internally threaded. Screws onto a full wave 10" (254 mm) long <sup>1</sup>/<sub>2</sub>" (13 mm) probe at the nodal point.



**PART NO.**  
**830-00014**

## SONOCHEMISTRY PROBE

<sup>1</sup>/<sub>2</sub>" (13 mm) special 10" (254 mm) long full wave solid probe. Used with the adapter above.



**PART NO.**  
**630-0217**





# VCX 130

130 Watts

Processing Volume: 200µl – 150mL\*

The **VCX 130** is a 130 watt, programmable ultrasonic processor and our most popular small volume system.

This model offers the same programmability as larger **VCX** versions.

The ¼" probe (10 – 50ml volumes) is included and a variety of accessories are available for various applications and sample volumes.

## FEATURES:

- Programmable
- Pulse mode
- 10 hour timer
- Variable power output
- Wattage and Energy display



(stand is optional)

Ordering information: Model no. **VCX 130**  
130 watt ultrasonic processor with ¼" diameter probe and tool kit.

## SPECIFICATIONS

Power Output	130 watt maximum	Converter Cable Length	Permanently attached 5 ft. (1.5m)
Frequency	20kHz		
Dimensions	H x W x D: 4.5 x 9.75 x 12.5" (115 x 250 x 320mm)		
Ultrasonic Converter	Part #CV18	Tool Kit	Part #888-00026 open end wrench (2 included)
Diameter	1.25" (32mm)		
Length	5.75" (146mm)		
Standard Probe	Part #630-0435	Optional:	
Tip Diameter	1/4" (6mm)	Stand with Clamp	Part #830-00460
Length	5.4" (137mm)	Sound Enclosure	Part #830-00451
Material	Ti6Al4V titanium alloy		



\*The actual processing volume of a specific probe or accessory is application specific.



# VCX 130PB

130 Watts

Processing Volume: 200µl – 150mL\*

The **VCX 130PB** is a 130 watt system with pulse button control. The probe can be handheld and ultrasonic energy manually activated by depressing the button on the side of the converter.

This is a cost effective alternative to the **VCX 130** version. The 1/8" probe (0.5 – 15mL volumes) is included and a variety of accessories are available for various applications and sample volumes.

## FEATURES:

- Variable power output
- Pulse button control
- Manual pulse mode
- Wattage and Energy display



(stand is optional)

Ordering information: Model no. **VCX 130PB**  
130 watt ultrasonic processor with 1/8" diameter probe and tool kit.

## SPECIFICATIONS

Power Output	130 watt maximum	Converter Cable Length	Permanently attached 6 ft. (1.8m)
Frequency	20kHz		
Dimensions	H x W x D: 4.5 x 9.75 x 12.5" (115 x 250 x 320mm)		
Ultrasonic Converter	Part #CV188 (with pulse button)	Tool Kit	Part #888-00026 open end wrench (2 included)
Diameter	1.25" (32mm)		
Length	5.75" (146mm)		
Standard Probe	Part #630-0422	Optional: Stand with Clamp	Part #830-00460
Tip Diameter	1/8" (3mm)	Sound Enclosure	Part #830-00451
Length	5.4" (137mm)		
Material	Ti6Al4V titanium alloy		



\*The actual processing volume of a specific probe or accessory is application specific.



# VC 50

50 Watts

Processing volume: 200µl – 50mL\*

The **VC 50** is a small and compact 50 watt ultrasonic processor. The probe can be held by hand and ultrasonic energy is activated by turning the amplitude knob on the front panel.

The 1/8" probe (0.5 – 15mL volumes) is included and a variety of accessories are available for various applications and sample volumes.

## FEATURES:

- Compact design
- Variable power output
- Low cost



Ordering information: Model no. **VC 50**  
50 watt ultrasonic processor with 1/8" diameter probe and tool kit.

## SPECIFICATIONS

Power Output	50 watt maximum	Converter Cable Length	Permanently attached 5 ft. (1.5m)
Frequency	20 kHz		
Dimensions	H x W x D: 8 x 8 x 5" (203 x 203 x 127mm)		
Ultrasonic Converter Diameter	Part #CV18 1.25" (32mm)	Tool Kit	Part #888-00026 open end wrench (2 included)
Ultrasonic Converter Length	5.75" (146mm)		
Standard Probe Tip Diameter	#630-0422 1/8" (3mm)	Optional: Stand with Clamp	Part #830-00460
Standard Probe Length	5.4" (137mm)	Sound Enclosure	Part #830-00451
Standard Probe Material	Ti6Al4V titanium alloy		



\*The actual processing volume of a specific probe or accessory is application specific.



# ACCESSORIES FOR 130 AND 50 WATT SYSTEMS

## PROBE OPTIONS

Probes amplify and radiate the ultrasonic energy into the sample. All probes are fabricated from titanium alloy Ti-6Al-4V and are autoclavable. Each ultrasonic processor includes a standard probe which can be substituted for a different size or accessory if requested.

**TIP DIAMETER**

5/64" (2mm)

**PART NO.**  
630-0423

**VOLUME**  
0.2-5mL

**AMPLITUDE**  
135µm

**TIP DIAMETER**

1/8" (3mm)

**PART NO.**  
630-0422

**VOLUME**  
0.5-15mL

**AMPLITUDE**  
170µm

**TIP DIAMETER**

1/4" (6mm)

**PART NO.**  
630-0435

**VOLUME**  
10-50mL

**AMPLITUDE**  
120µm

**TIP DIAMETER**

1/2" (12mm)

**PART NO.**  
630-0504

**VOLUME**  
50-150mL

**AMPLITUDE**  
45µm

Only for 130W models

## SUPPORT STAND WITH CLAMP

Securely support your ultrasonic processor with a chemically resistant plastic holder on a 5.5" x 9" cast-iron base with 0.5" diameter rod.

The converter clamp and support stand can be ordered separately.



**PART NO.**  
830-00460



**PART NO.**  
830-00118

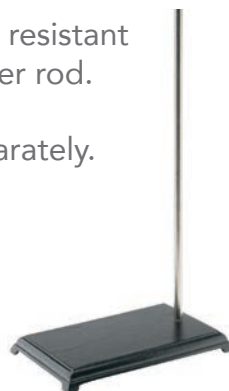

**PART NO.**  
830-00109

## SOUND ABATING ENCLOSURE

Ultrasonic processing produces high pitched noise, which originates from the vessel walls and the liquid surface. The sound enclosure reduces the noise to comfortable levels. A support rod and converter clamp are included. Access ports are available on both sides and the top of the enclosure.

**OUTSIDE DIMENSIONS:**

(H x W x D) 20" x 12" x 12" (508 x 305 x 305 mm)

**INSIDE DIMENSIONS:**

(H x W x D) 18.5" x 11" x 11" (470 x 280 x 280 mm)



**PART NO.**  
830-00451

## FOOTSWITCH

For hands-free operation with 10' (3m) cable.



**PART NO.**  
830-00004

VCX 130 and VC 50 only





### EIGHT ELEMENT PROBE

The eight-element probe increases productivity and minimizes repetitive tasks by processing 8 samples simultaneously. Recommended for use in 96 well plates.

**SPACING BETWEEN TIPS**

1 1/32" (9 mm)

**TIP LENGTH**

1/16" (17 mm)

**TIP DIAMETER**

1/8" (3 mm)

**PART NO.**  
630-0602

Only for 130W models

### LOW VOLUME CONTINUOUS FLOW CELL

The continuous flow cell screws into the converter in place of the probe. This system is recommended for the treatment of low viscosity samples that require short processing times. The main body is glass and the probe and processing chamber are titanium. The volume of liquid needed to fill the chamber is 35 ml.

Outlet connects to 1/2" (13 mm) I.D. tubing.

Inlet connects to 3/8" (9.5 mm) I.D. tubing.



**PART NO.**  
630-0566

Only for 130W models



### CUP HORN

The cup horn can process small samples in isolation without probe intrusion, removing the risk of cross contamination or aerosolization. This is especially useful when working with infectious materials.

The water-filled micro cup horn screws into the inverted converter in place of a probe. A tube containing the sample is placed inside the cup horn. The vibrations produced in the cup induce cavitation inside the tube. Inlet and outlet ports enable cooling water to be recirculated within the cup, inhibiting heat build-up during extended operation. A holder for 1.5mL tubes is included.

Outlet connects to 1/2" (13 mm) I.D. tubing.

Inlet connects to 3/8" (9.5 mm) I.D. tubing.

**PART NO.**  
630-0608

Only for 130W models

### ROSETTE GLASS COOLING CELLS

The rosette is a glass cell that enables uniform treatment at low temperatures. Fill the rosette with your liquid sample and place it in an ice bath. The ultrasonic energy forces the sample to circulate under the probe and through the cooling arms.



300mL Rosette

**PART NO.**  
830-00001

30mL Rosette

**PART NO.**  
830-00003



### JACKETED BEAKERS

The jacketed beaker is attached to a chiller or another cold water source. The chilled water is circulated around the liquid within the beaker maintaining the desired sample temperature.

10mL cooling cell with water jacket

**PART NO.**  
830-00009

100mL cooling cell with water jacket

**PART NO.**  
830-00010







# VCX 1500

1500 Watts  
Processing Volume: 1 – 10L\*

The **VCX 1500** is a reliable and durable choice for many applications. This model includes a 1" diameter, 10" long probe with a 100µm maximum amplitude.

A variety of probe options are available including the flow cell inline processing accessory. Electrical requirements are 220V, 50/60Hz, single phase, 20A.

## FEATURES:

- Programmable
- Variable power output
- 10 hour timer
- Pulse mode
- Wattage and Energy display
- Temperature monitoring
- Energy setpoint



Ordering information: Model no. **VCX 1500**

1500 watt ultrasonic processor with 1" diameter probe, booster and tool kit.

Note: Air cooling of the converter by a compressed air source is required. The user must provide approximately 10psi (5 cfm) of clean, dry air to prevent overheating of the ultrasonic processor.

## SPECIFICATIONS

Power Output	1500 watt maximum	Booster (2:1)	Part #BHN294T21
Frequency	20kHz	Length	5" (129mm)
Dimensions	H x W x D: 7 x 15 x 18.25" (178 x 380 x 464mm)	Converter Cable	Part #201-0106
		Length	10' (3m)
Ultrasonic Converter	Part #CV294	Tool Kit	Part #888-00054 spanner wrench (2 included)
Diameter	3" (76.2mm)		
Length	6.25" (159mm)		
Standard Probe	Part #630-0697	Optional:	
Tip Diameter	1" (25mm)	Stand with Clamp	Part #830-00461
Material	Ti6Al4V titanium alloy	Temperature Probe	Part #830-00060
		Sound Enclosure	Part #830-00474



\*The actual processing volume of a specific probe or accessory is application specific.



# HIGH VOLUME CONTINUOUS FLOW CELL

The flow cell enables large volume, continuous processing. The throughput rate depends on many variables including viscosity and desired degree of processing. The flow cell is recommended for the treatment of low viscosity samples which do not require extended exposure to ultrasonics. For optimum performance, when working on a flow through basis, pre-mixing the sample with a mechanical stirrer is recommended. Multiple units can be used in series to reduce processing time and/or maintain higher flow rates.

The liquid sample is pumped into the flow cell through the inlet at the bottom of the unit. As the sample passes through the cavitation field, it is processed. The processed liquid exits the unit through an outlet port. The degree of processing can be controlled by adjusting the intensity of sonication as well as flow rate.

The flow cell is easily disassembled for inspection and cleaning, and is water jacketed to enable the sample to be cooled while it is being processed. All wetted parts are autoclavable.

**HIGH VOLUME FLOW CELL WITH HIGH EFFICIENCY PROBE**

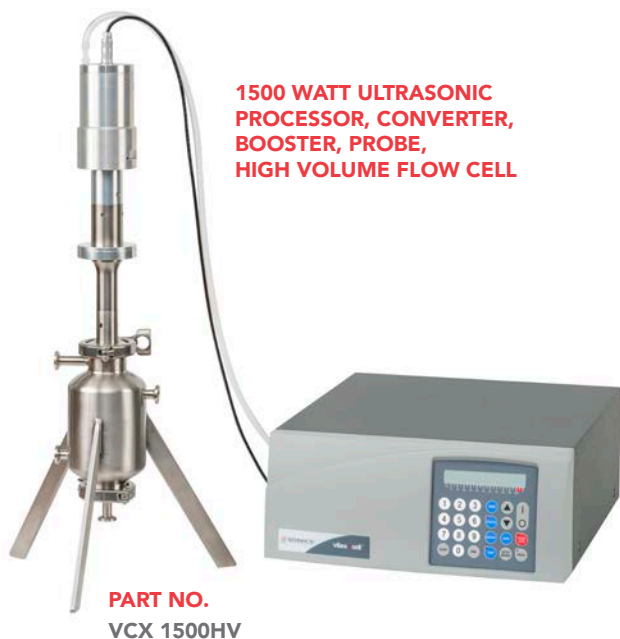
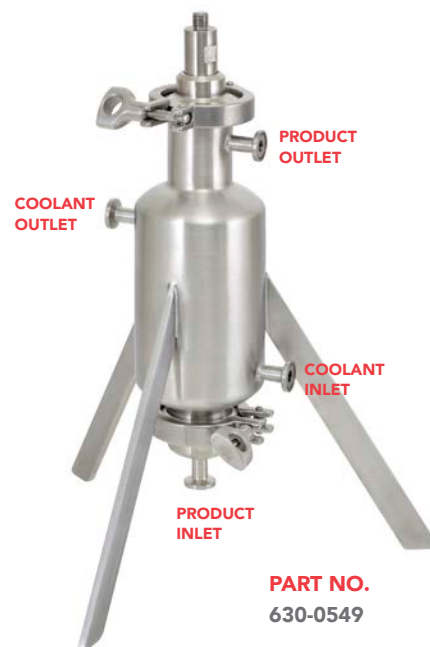

**1500 WATT ULTRASONIC PROCESSOR, CONVERTER, BOOSTER, PROBE, HIGH VOLUME FLOW CELL**

**HIGH EFFICIENCY FLOW CELL PROBE**



**PART NO. 630-0625**

**SOUND ENCLOSURE FOR VCX 1500HV**



(H X W X D) 38" X 18" X 17.75"  
(965 X 457 X 451 mm)

**PART NO. 830-00474**

## FLOW CELL SPECIFICATION

Material:	316 stainless steel
Height:	17" (432 mm)
Width:	16" (406 mm)
Weight:	12 lbs. (5.5 kg)

Operating pressure:	Up to 100 psi
Internal volume w/probe:	400 mL
Product/Coolant Connectors:	1/2" (13 mm) sanitary





# VCX 2500

2500 Watts  
Processing Volume: 10 – 50L\*

The **VCX 2500** is our highest power system for the most difficult applications. This model includes a 1.5" diameter, 15" long probe with a 100µm maximum amplitude.

A variety of probe options are available including the flow cell inline processing accessory. Electrical requirements are 220V, 50/60Hz, single phase, 30A.

## FEATURES:

- Programmable
- Variable power output
- 10 hour timer
- Pulse mode
- Wattage and Energy display
- Temperature monitoring
- Energy setpoint



Ordering information: Model no. **VCX 2500**

2500 watt ultrasonic processor with 1.5" diameter probe, booster and tool kit.

Note: Air cooling of the converter by a compressed air source is required. The user must provide approximately 10psi (5 cfm) of clean, dry air to prevent overheating of the ultrasonic processor.

## SPECIFICATIONS

Power Output	2500 watt maximum	Booster (2.5:1)	Part #BHN294T25
Frequency	20kHz	Length	5" (129mm)
Dimensions	H x W x D: 9 x 17.5 x 28" (240 x 445 x 711mm)	Converter Cable	Part #201-0106
		Length	10' (3m)
Ultrasonic Converter	Part #CV294	Tool Kit	Part #888-00054 spanner wrench (2 included)
Diameter	3" (76.2mm)		
Length	6.25" (159mm)		
Standard Probe	Part #630-0702	Optional:	
Tip Diameter	1.5" (38mm)	Stand with Clamp	Part #830-00461
Material	Ti6Al4V titanium alloy	Temperature Probe	Part #830-00060



\*The actual processing volume of a specific probe or accessory is application specific.



Sonics offers a variety of miniaturized ultrasonic processor kits and accessories to serve the **OEM MARKET**. We assist a variety of customers in medical diagnostics, particle size analysis and other various industries. Circuit boards, converters and probes are available in different shapes, sizes and ultrasonic frequencies.

With over 50 years of experience, Sonics has built a solid reputation for high quality and reliable equipment. This expertise gives our customers the confidence to incorporate ultrasonics into many types of devices such as point of care diagnostic instruments.

Our engineering team is ready to discuss your application and if one of our many standard items does not solve the issue, we have the ability to customize as needed.

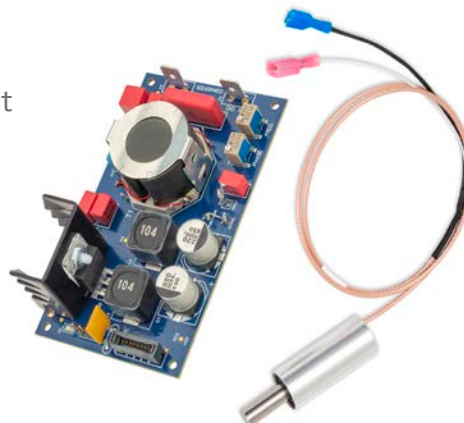

### 50 WATT ULTRASONIC BOARD (40KHZ)

(with mounting plate)

Overall dimension: 4.75" (120.7mm) W x 4.75" (120.7mm) L x 2.2" (56mm) H

4 Mounting holes - .200" (5mm):  
2.75" (70mm) x 3.45" (88mm)

**PART NO.**  
KITVC544



### 100 WATT ULTRASONIC BOARD (40KHZ)

(with mounting plate)

Overall dimension: 4.5" (114.3mm) W x 7.5" (190.5mm) L x 2.2" (56mm) H

4 Mounting holes - .156" (3.96mm):  
4.2" (106.68mm) x 7.2" (182.88mm)

**PART NO.**  
KITVC1044





# ATOMIZER



Unlike conventional spray nozzles that rely on high velocity pressure to shear a fluid into small drops, the ultrasonic atomizer uses vibrational energy to generate a low velocity mist. Volumes can vary from microliters to liters, and atomize continuously or intermittently.

The liquid travels through the probe and spreads out as a thin film on the atomizing surface. The ultrasonic vibrations are intensified by the probe and focused at the tip where the atomization takes place. The oscillating tip disintegrates the liquid into micro-droplets, and releases them to form a gentle, low velocity spray. Median droplet size is 50µm.



**PART NO.**  
VCX 134ATA

- Continuous or intermittent spray
- Dispense with minimum overspray
- Pressureless, low velocity atomization
- Multiple probe options
- 40 kHz frequency
- Clog resistant

## NARROW DISPERSION PROBE

**PART NO.**  
630-0667



## WIDE DISPERSION PROBE

**PART NO.**  
630-0668



## DUAL INLET PROBE

**PART NO.**  
630-0654



A PROBE IS NOT INCLUDED AND MUST BE ORDERED SEPARATELY.







# FREQUENTLY ASKED QUESTIONS

## WHAT IS ULTRASONICS?

Although sound is the sensation perceived by the sense of hearing, it is not always audible. Ultrasound literally means beyond sound; sound above the human audible spectrum. The frequency of a sound is the number of cycles of a sound wave in one second. Frequency is measured in units called hertz (Hz). Since 18 kHz (18,000 Hertz/cycles) per second is the approximate upper limit of human audibility, ultrasonics refers to sound (acoustic waves) beyond that frequency. 20 kHz is the most effective frequency for liquid processing applications.

## WHAT ARE THE DIFFERENCES BETWEEN AN ULTRASONIC PROCESSOR AND AN ULTRASONIC BATH?

The ultrasonic intensity within a bath is low power, location dependent, and inconsistent, due to many factors. With an ultrasonic processor, processing is significantly faster and highly reproducible, due to the fact that the energy at the probe tip is high intensity, focused and adjustable.

## 20 KHZ OR 40 KHZ?

40 kHz is commonly used for ultrasonic cleaning and atomization because the droplet size at that frequency is half that generated at 20 kHz. However, the frequency of choice for most ultrasonic liquid processing applications is 20 kHz, because the amplitude at the probe tip and the resulting cavitation is more effective for liquid processing. 40 kHz may be effective for small volumes and some short duration applications such as many OEM situations.

## WITH ULTRASONIC PROCESSING, ARE THERE ANY LIMITATIONS?

Yes - viscosity, temperature and liquid characteristics. As the viscosity of the material increases, its ability to transmit vibrations decreases. Typically, the maximum viscosity at which a material can be processed effectively is 4000 cps. With standard systems, the practical upper limit on temperature is approximately 65°C. Solid tipped probes can be used with both aqueous solutions and low surface tension liquids (e.g. solvents), however probes with replaceable tips are only used with aqueous samples.

## WHICH INSTRUMENT SHOULD I USE?

The 500 and 750 watt units are the most versatile because they can process both large and small volumes – as little as 250µl with a microtip, and as much as 1 liter with a 1" (25 mm) probe. Additionally, they can process many liters per hour on a flow-through basis when used with a continuous flow cell. If your sample volume is small, a 130 watt unit is likely the best option. The 1500 or 2500 watt units are recommended for large scale and industrial applications.

## WHICH PROBE IS BEST SUITED FOR MY APPLICATION?

The larger the probe diameter and higher the amplitude, the larger the volume that can be processed. Smaller probes are needed to fit into smaller vessels. See probe listings for guidelines and contact us for assistance in selecting the correct options.

## CAN PROBES BE MANUFACTURED TO ANY LENGTH?

No. Probes are made to resonate at a specific frequency (half a wavelength or multiples of half wavelength). 20 kHz probes are approximately 5" (127 mm) long and can be made longer in 5" (127 mm) increments.





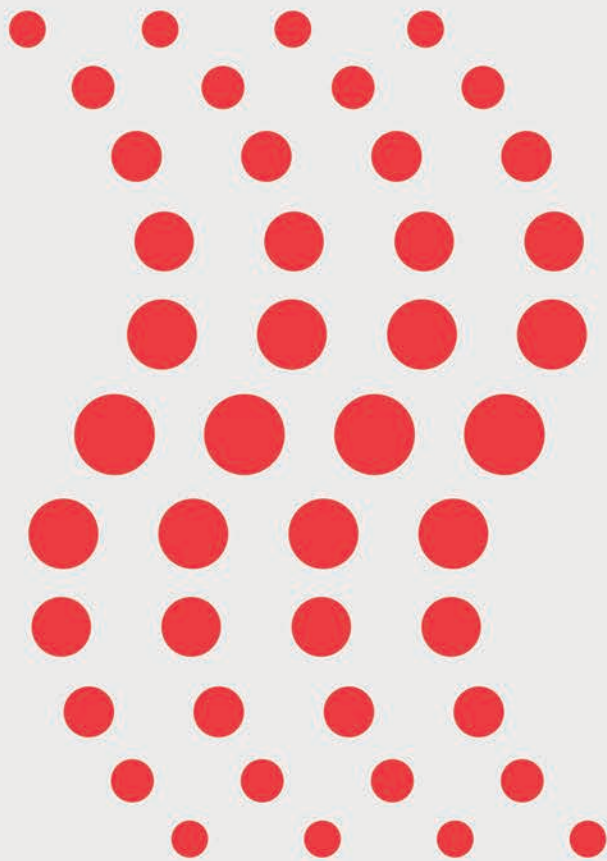

sonics.com  
203.270.4600  
info@sonics.com

53 Church Hill Road  
Newtown, CT 06470

rev 8.2021



**SONICS**<sup>®</sup>  
SONICS & MATERIALS, INC.